

B 20-02 2mm scale LNER style signal box

All drawings are not in scale. Some proportions on drawings may differ from reality.

**This kit can be assembled with either left or right stair option out of the box
Left version show in this manual**

For additional elements for modification and extension please visit our website at www.lcut.co.uk or email us at contact@lcut.co.uk

Footprint: Width: 72mm Depth: 28mm
Cabin only: Width: 44mm Depth: 24mm

! We recommend PVA/wood glue or Deluxe Materials Laser Kit Glue for the main fibre board/MDF parts and resin based/CA glue for 3D printed parts if present.

Painting recommendation: We recommend using acrylic or enamel paints. The MDF parts if this kit require undercoating with a suitable primer. If you experience any warping on the material leave it to fully dry and then gently bend it back into shape. Always test any paints in an area that will not be seen or on spare parts/off cuts.

Parts list breakdown can be found on the last 2 pages of this manual.

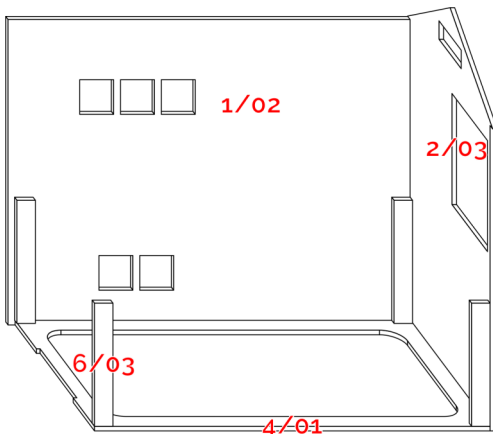

Start the assembly by joining one of the two walls together. Add the bottom floor bracket. Add the rest of the walls as well as the floor spacers (6-03).

We recommend to paint the cabin and its inside at this step.

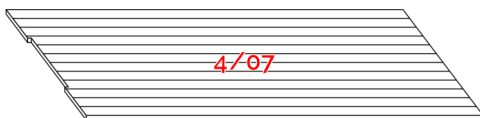

Paint the floor separately and fit it into the cabin.

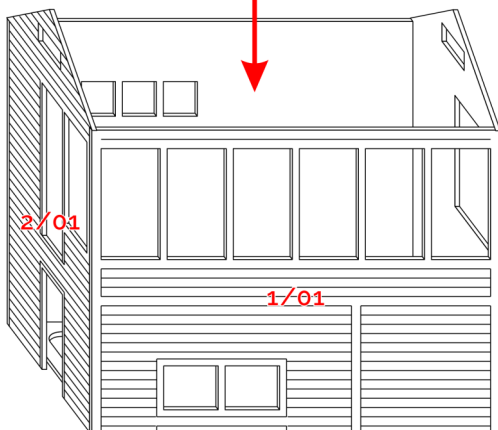

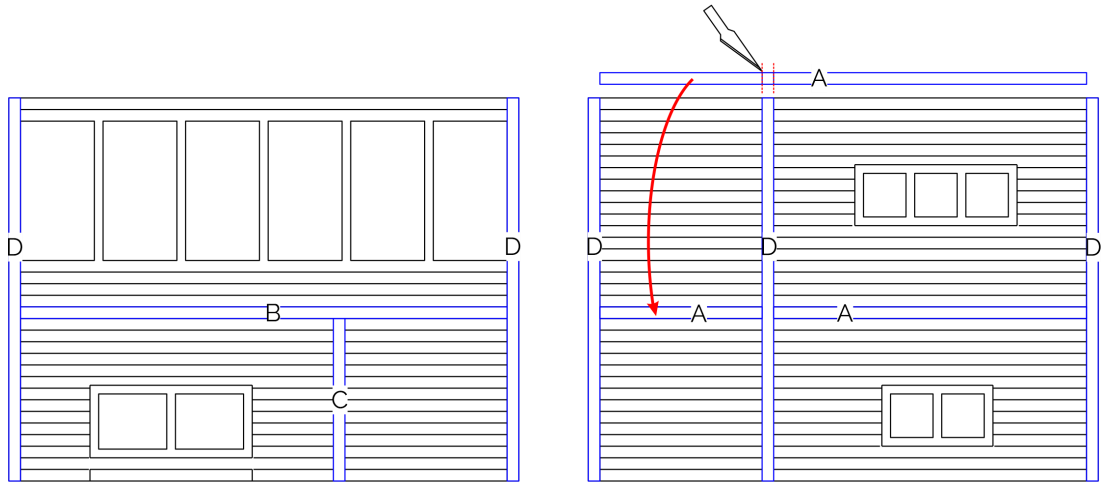
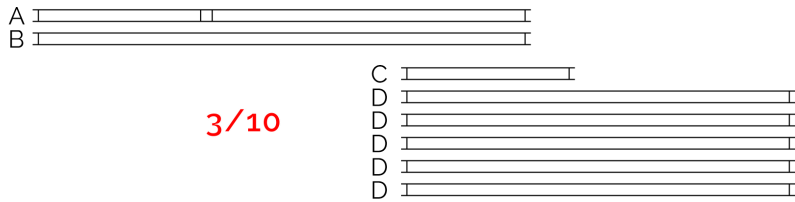

Pre paint the woodwork framing before gluing it to the cabin. Note the position of each element on diagram above. Element "A" needs a piece cutting out before fitting (to fit between element "D").

Pre paint the windows and doors and then fit them into the cabin in positions shown on the drawing below.

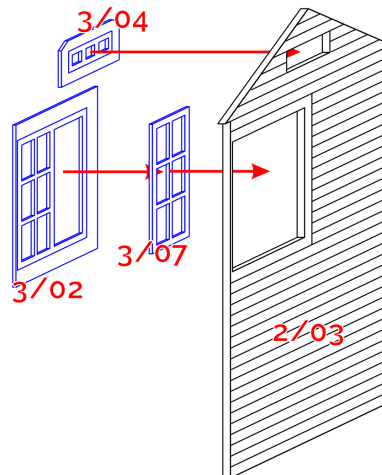
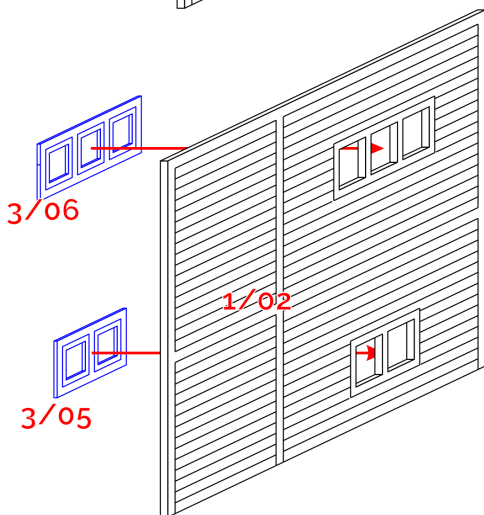
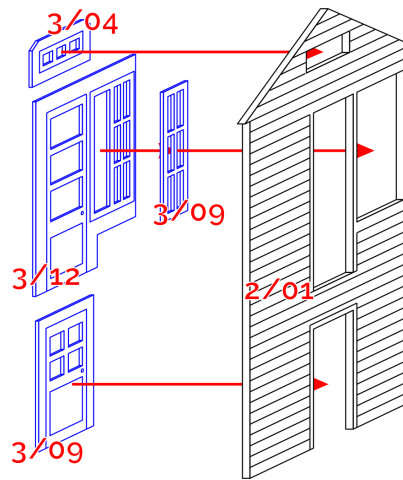
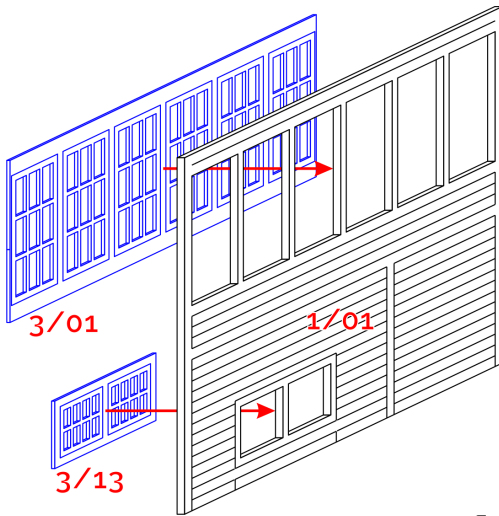

The roof needs to be gently scored in the middle to make it easier to bend. The ridge tiles need to be scored along the middle to make them easier to fold.

Assemble the roof as shown on the drawing below. Ensure the barge boards (5/02) are set in to the same depth as the cut out in the main roof tile panel. Add the finials.

Assemble the balcony making sure to position the support brackets so that they miss the lower window.

The staircase is assembled by gluing the sides to the 3D printed core and then adding on the perpendicular railing (note if assembling the right stair version assemble mirrored).

The priv is assembled by joining the 4 walls, adding the roof, and finishing with roof tiles. Ensure the priv roof is flush with the back wall of the priv so that it can be glued onto the signal box flush.

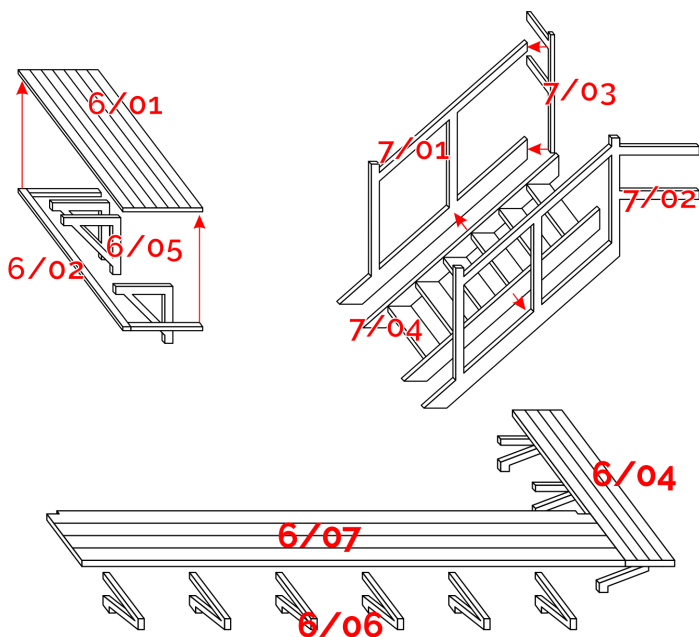
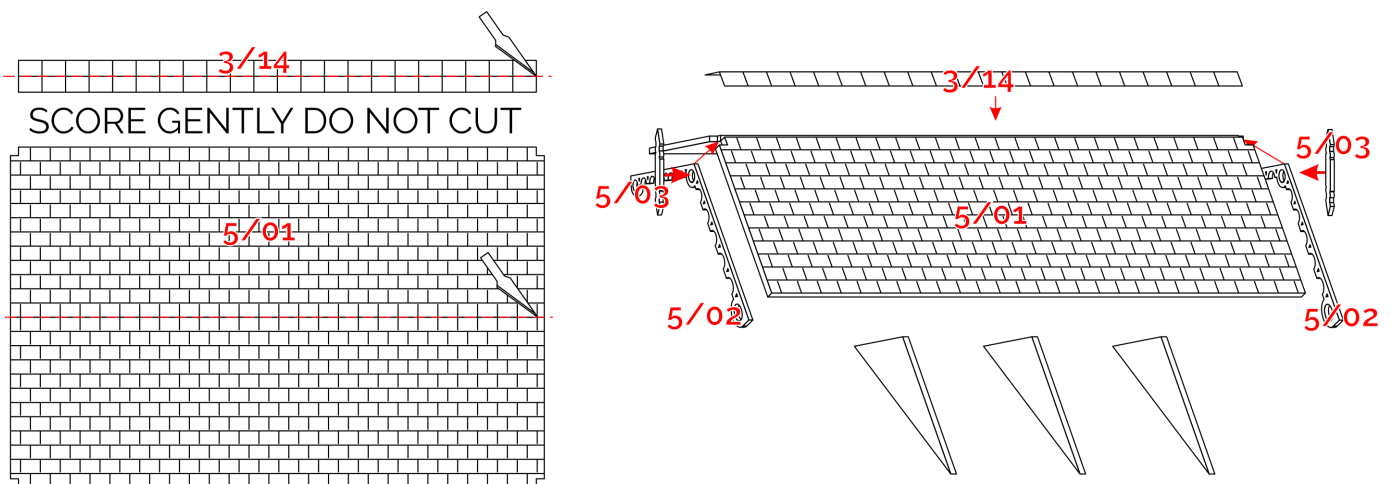

SCORE GENTLY DO NOT CUT

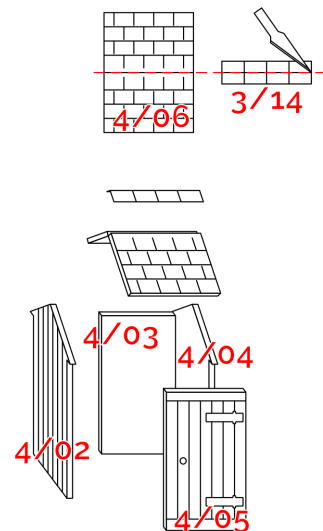

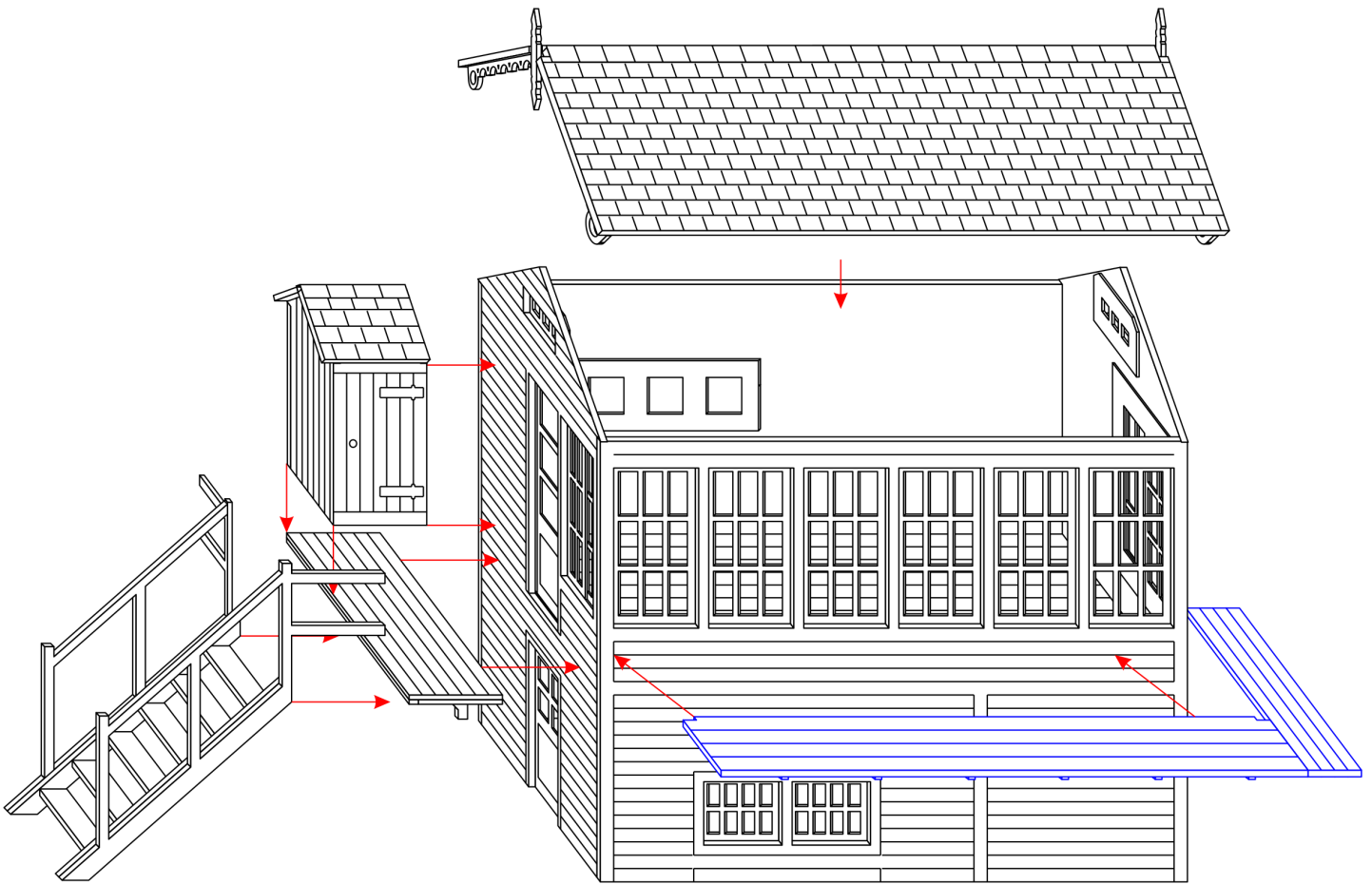

Perform the final assembly of the signal box by gluing the pre made assemblies to the cabin.

Note the balcony with priv needs to be glued level with the bottom of the main door.

The railing on the staircase should overlap the priv on the perpendicular side and be flush an even with the front wall on the other side.

The window walkway needs to be glued on about 2 planks from the windows.

The roof can be left removable and if assembled right should sit evenly on the walls.

B 20-02 fret part reference sheet

